

Mobile Media Center for Flat-Screen TV - One-Touch Height Adjustment

STNDMTV70



*actual product may vary from photos

FR: Guide de l'utilisateur - fr.startech.com

DE: Bedienungsanleitung - de.startech.com

ES: Guía del usuario - es.startech.com

NL: Gebruiksaanwijzing - nl.startech.com

PT: Guia do usuário - pt.startech.com

IT: Guida per l'uso - it.startech.com

For the latest information, technical specifications, and support for this product, please visit www.StarTech.com/STNDMTV70.

Use of Trademarks, Registered Trademarks, and other Protected Names and Symbols

PHILLIPS® is a registered trademark of Phillips Screw Company in the United States or other countries.

This manual may make reference to trademarks, registered trademarks, and other protected names and/or symbols of third-party companies not related in any way to StarTech.com. Where they occur these references are for illustrative purposes only and do not represent an endorsement of a product or service by StarTech.com, or an endorsement of the product(s) to which this manual applies by the third-party company in question. Regardless of any direct acknowledgement elsewhere in the body of this document, StarTech.com hereby acknowledges that all trademarks, registered trademarks, service marks, and other protected names and/or symbols contained in this manual and related documents are the property of their respective holders.

Warning statements

Make sure that you assemble this product according to the instructions.

Read the entire manual and make sure that you understand the instructions before you start to assemble and use this product.

Do not exceed the weight capacity of this product. Overloading this product might result in injury or property damage.

Weight capacity of the multimedia shelf: 5 kg (11 lb.)

Weight capacity of the camera shelf: 5 kg (11 lb.)

Weight capacity of the TV mount: 8-20 kg (18-44 lb.)

Do not allow children to climb on this product, or use this product without proper supervision.

This product is intended for indoor use only and should not be used outdoors.

When you assemble this product, do not over-tighten the screws. If you encounter resistance when you are tightening the screws, stop tightening.

Assembling this product is a two-person task. Do not attempt to assemble this product and install equipment without assistance.

Before you add equipment to this product, make sure that you have properly assembled and installed it, and that the product can support the weight of the equipment that you are adding to it.

Make sure that you properly install all of your equipment before you start to adjust this product.

For safety reasons, when you add or remove equipment and change the weight of the mounted load, you need to follow the steps in the manual to readjust this product.

Stored energy hazard! The column in this product contains a lift mechanism that could move up quickly when you remove the loaded equipment. Before you remove equipment or make adjustments to the lift tension, move the display to the highest position on the column. Failure to do so could result in injury or property damage.

Tipping hazard! Do not move the cart while the display is in the highest position. Also, do not move the cart by pushing on the display.

Do not move the cart over cords, cables, or uneven surfaces.

Before you start to move the cart, make sure that you unlock the casters.

Varningsmeddelanden

Se till att du monterar produkten i enlighet med instruktionerna.

Läs hela manualen och se till att du förstär instruktionerna innan du börjar montera och använda produkten.

Överskrid inte produktens viktkapacitet. Överbelastning av produkten kan orsaka skada på person eller egendom.

Viktkapacitet multimedia hylla: 5 kg

Viktkapacitet kamera hylla: 5 kg

Viktkapacitet fäste för TV: 8-20 kg

Låt inte barn klättra på produkten eller använda produkten utan uppsikt.

Produkter är endast avsedd för användning inomhus och ska inte användas utomhus.

Drä inte åt skruvarna för hårt när du monterar produkten. Om du måste ta i när du skruvar åt kan du sluta skruva åt.

Det krävs två personer för att montera produkten. Försök inte montera produkten och installera utrustning utan hjälp.

Innan du lägger till utrustning på produkten, se till att produkten är korrekt monterad, installerad och att produkten klarar av vikten på utrustningen som du lägger till.

Se till att all utrustning är korrekt installerad innan du börjar justera produkten.

För säkerhets skull måste du följa stegen i manualen för att justera om produkten när du lägger till eller tar bort utrustning och ändrar den belastade vikten.

Risk för lagrad energi! Kolumnen i detta produkt innehåller en lyftmekanism som kan åka upp snabbt om du tar bort utrustning. Innan du tar bort utrustning eller justerar lyftspänningen, flytta skärmen till högsta positionen på kolumnen. Om du inte gör det kan skada på person eller egendom uppstå.

Risk för flyttning! Innan du vagnar med skärmen är vid den högsta positionen. Flytta heller inte vagnen genom att trycka på skärmen.

Flytta inte vagnen över kablar eller ojämna ytor.

Innan du börjar flytta på vagnen, se till att hjulen är upplåsta.

Waarschuwingen

Zorg dat u dit product volgens de instructies in elkaar zet.

Lees de gehele handleiding en zorg dat u de instructies begrijpt voordat u dit product in elkaar zet en gebruikt.

Overschrijd de maximale capaciteit van dit product niet. Overbelasting van dit product kan letsel of materiële schade veroorzaken.

Gewichtscapaciteit van het multimedia oppervlak: 5 kg

Gewichtscapaciteit van het bovenste oppervlak (voor camera): 5 kg

Gewichtscapaciteit van de schermbevestiging (voor televisie): 8-20 kg

Geef kinderen geen toestemming om op dit apparaat te klimmen of dit product zonder goed toezicht te gebruiken.

Dit product is alleen bedoeld voor binnengebruik. Er mag niet buiten worden gebruikt.

Draai de schroeven niet te strak vast wanneer u dit product in elkaar zet. Als u weerstand voelt tijdens het vastdraaien van de schroeven, stop dan.

Dit product moet met twee personen in elkaar worden gezet. Probeer dit product niet zonder hulp in elkaar te zetten en apparatuur te installeren.

Voordat u apparatuur aan dit product toevoegt, moet u ervoor zorgen dat u het op de juiste manier in elkaar hebt gezet en geïnstalleerd, en dat het product het gewicht van de toe te voegen apparatuur kan ondersteunen.

Zorg dat u de apparatuur goed installeert voordat u met het aanpassen van dit product begint.

Om veiligheidsredenen, wanneer u apparatuur toevoegt of verwijderd en het gewicht van de gemonteerde last verandert, moet u de stappen in de handleiding volgen voor het aanpassen van dit product.

Gevaar van opgeslagen energie! De kolom in dit product bevat een lyftmechanisme dat snel omhoog zou kunnen bewegen wanneer u de aangebrachte apparatuurafslaat verwijdert. Voordat u apparatuur verwijdert of verandert, moet u de display naar de hoogste positie op de kolom verplaatsen. Anders zou lichamelijk letsel of materiële schade kunnen ontstaan.

Kantelgevaar! Verplaats de vagnen niet terwijl het product in de hoogste positie staat. Verplaats de vagnen ook niet door tegen het scherm te duwen.

Rijd de vagnen niet over snoeren, kabels of ongelijke oppervlakken.

Voordat u de vagnen gaat verplaatsen, moet u de zwenkwielen ontgrendelen.

注意

必ず取扱説明書に従って本製品の組み立てを行って下さい。

最初に取扱説明書を最後まで読み、本製品の組み立て方をすべて理解してから組み立て作業を始めて下さい。

本製品で定められた最大積載重量を超えないようにして下さい。最大積載重量をオーバーした場合は、怪我をする恐れや器物破損の恐れがあります。

マルチメディア棚の総耐荷重:5kg

カメラ棚の総耐荷重:5kg

TVマウンタの総耐荷重:20kg

本製品に小さなお子様が乗って遊ばないようにして下さい。お子様が使用する際には、適切な監視を怠らないようにして下さい。

本製品は、室内での使用を想定しています。戶外では使用しないで下さい。

本製品を組み立てる際、ネジを締めすぎないようにして下さい。ネジを締めているうちに手応えを感じたら、締めるのを止めてください。

本製品は、二人がかりでの組み立てを想定しています。手助けなしに単独で組み立てと設置を行わないで下さい。

本製品に装置を積載する前に、組み立てと設置が適切に行われたか確認して下さい。また、積載する装置の重量に本製品が対応しているか確認して下さい。

本製品の調整を行う前に、すべての装置が適切に設置されているか確認して下さい。

安全性を考慮し、装置を着脱する際、および積載負荷を変更する際には、取扱説明書の指示に従い本製品を再度調整して下さい。

反動注意!本製品の支柱には、リフト機構が組み込まれており、積載した装置を取り外すと反動で急速に上昇する可能性があります。装置の取り外しやリフトのテンションを調整する前に、支柱の最も高い位置にモニタを移動させて下さい。この操作を怠ると怪我をする恐れや器物破損の恐れがあります。

転倒注意!モニタが一番高い位置にある状態でカートを動かさないで下さい。また、モニタを押してカートを動かすのはやめて下さい。

コードやケーブルの上、または凹凸のある床面でカートを移動させないで下さい。

カートを動かす前に、キャスタのロックが解除されているか確認して下さい。

Dichiarazioni di avvertenza

Assicurarsi di Assemblare il prodotto secondo le istruzioni.

Leggere l'intero manuale e assicurarsi di aver compreso tutte le istruzioni prima di iniziare ad assemblare e utilizzare questo prodotto.

Non superare la capacità di carico del prodotto. Il sovraccarico del prodotto potrebbe causare danni o lesioni.

Portata massima del ripiano multimediale: 5 kg

Portata massima del ripiano per camera: 5 kg

Portata massima del supporto per TV: 8-20 kg

Non consentire ai bambini di arrampicarsi sul prodotto o di utilizzarlo senza un'adeguata supervisione.

Il prodotto è destinato all'uso in ambienti interni. Se ne sconsiglia l'impiego in ambienti esterni.

Durante l'assemblaggio del prodotto, non stringere troppo le viti. Se si incontra resistenza mentre si stringono le viti, interrompere l'operazione.

L'assemblaggio di questo prodotto richiede la presenza di due persone. Non tentare di assemblare il prodotto e installare le apparecchiature senza assistenza.

Prima di aggiungere altre apparecchiature al prodotto, assicurarsi di averlo assemblato e installato correttamente e che sia in grado di sostenere il peso dell'apparecchiatura in questione.

Dichiarazioni di avvertenza

Assicurarsi di aver installato correttamente tutte le apparecchiature prima di procedere alla regolazione del prodotto.

Per motivi di sicurezza, quando si agganciano o si rimuovono apparecchiature e varia il peso del carico sul supporto, è necessario attenersi alla procedura descritta nel manuale per regolare di nuovo il prodotto.

Pericolo di energia accumulata! La colonna di questo prodotto include un meccanismo di sollevamento che potrebbe scattare rapidamente verso l'alto quando si rimuove l'apparecchiatura caricata. Prima di rimuovere l'apparecchiatura o di regolare la tensione di sollevamento, spostare il display nella posizione più elevata sulla colonna. L'inservenza di questa indicazione potrebbe causare danni o lesioni.

Pericolo di ribaltamento! Non spostare il carrello mentre il display è nella posizione più elevata. E non sposterlo spingendo il display.

Non far passare il display sopra corde, cavi o superfici irregolari.

Prima di procedere allo spostamento del carrello, verificare di aver sbloccato le rotelle.

Avertissements

Assemblez ce produit conformément aux instructions.

Lisez tout le manuel et assurez-vous que vous comprenez les instructions avant de commencer à assembler et utiliser ce produit.

Ne dépassez pas la capacité pondérale du produit. Une surcharge du produit peut entraîner des blessures ou des dommages matériels.

Capacité de poids de l'étagère multimédia : 5 kg

Capacité de poids de l'étagère pour caméra : 5 kg

Capacité de poids du support d'écran : 8-20 kg

N'autorisez pas les enfants à grimper sur ce produit ni à l'utiliser sans surveillance.

Ce produit est uniquement destiné à une utilisation en intérieur et ne doit pas être utilisé à l'extérieur.

Ne serrez pas trop les vis lors de l'assemblage de ce produit. Si vous rencontrez une résistance lors du serrage des vis, cessez de serrer.

L'assemblage de ce produit nécessite deux personnes. Ne tentez pas d'assembler le produit et d'installer les équipements sans aide.

Avant d'ajouter des équipements au produit, vérifiez que vous l'avez correctement assemblé et installé, et que le produit peut supporter le poids des équipements que vous y ajoutez.

Veillez à installer correctement tous les équipements avant de commencer à utiliser le produit.

Pour des raisons de sécurité, lorsque vous ajoutez ou retirez des équipements et modifiez le poids de la charge montée, vous devez suivre la procédure indiquée dans le manuel pour réajuster le produit.

Risque d'énergie emmagasinée! La colonne de ce produit contient un mécanisme de levage susceptible de s'élever rapidement lorsque vous retirez les équipements montés. Avant de retirer des équipements ou d'ajuster la tension de levage, placez l'écran à la position la plus élevée sur la colonne. Si vous ne respectez pas ces instructions, vous risquez de vous blesser ou d'endommager l'équipement.

Risque de basculement! Ne déplacez pas le meuble lorsque l'écran est à la position la plus élevée. Ne déplacez pas non plus le meuble en poussant sur l'écran.

Ne faites pas rouler le meuble sur des cordons, des câbles ou des surfaces inégales.

Avant de déplacer le meuble, veillez à débloquer les roulettes.

Mensagens de aviso

Certifique-se de que montou este produto de acordo com as instruções.

Leia todo o manual e certifique-se de que entende as instruções antes de começar a montar e a utilizar este produto.

Não exceda a capacidade de peso deste produto. Sobrecarregar este produto pode resultar em ferimentos ou danos de propriedade.

Capacidade de carga de la bandeja multimedia: 5 kg

Capacidade de carga de la bandeja de cámara: 5 kg

Capacidade de carga de suporte para TV: 8-20 kg

Não deitar as crianças near neste produto ou utilizar este produto sem a devida supervisão.

Este produto destina-se apenas a uma utilização no interior e não deve ser utilizado no exterior.

Quando montar este produto, não aperte demasiado os parafusos. Se encontrar resistência enquanto aperta os parafusos, pare de apertar.

Montar este produto é uma tarefa para duas pessoas. Não tentar montar este produto e instalar o equipamento sem assistência.

Antes de adicionar o equipamento a este produto, certifique-se de que o montou e instalou devidamente e de que o produto pode suportar o peso do equipamento que está a adicionar ao mesmo.

Certifique-se de que instala devidamente todo o seu equipamento antes de começar a ajustar este produto.

Por motivos de segurança, quando adicionar ou remover equipamento e mudar o peso da carga montada, precisa de seguir os passos no manual para reajustar este produto.

Perigo de energia armazenada! A coluna neste produto contém um mecanismo de elevação que pode mover rapidamente quando remover o equipamento descarregado. Antes de remover equipamento ou fazer ajustes na tensão de elevação, mover o ecrã para a posição mais alta na coluna. O incumprimento destas instruções pode resultar em ferimentos ou danos de propriedade.

Perigo de queda! Não mova o carro enquanto o ecrã está na posição mais alta. Além disso, não mova o carro empurrando o visor.

Não mova o carro pelos fios, cabos ou superfícies irregulares.

Antes de começar a mover o carro, certifique-se de que desbloqueia os rodízios.

Advertencias de uso

Asegúrese de ensamblar este producto según las instrucciones.

Leia todo o manual e assegure-se de haber comprendido bien las instrucciones antes de proceder con el ensamblaje y el uso de este producto.

Asegúrese de no exceder la capacidad de peso de este producto. La sobrecarga de este producto puede causar lesiones personales o daños en la propiedad.

Capacidad de carga del estante multimedia: 5 kg

Capacidad de carga del estante de la cámara: 5 kg

Capacidad de carga del soporte de TV: 8-20 kg

No permita que los niños se suban a este producto o que lo utilicen sin la debida supervisión de un adulto.

El uso de este producto es solo para interiores y no debe utilizarse en exteriores.

Cuando ensamble este producto, no apriete los tornillos más de lo debido. Si al apretar los tornillos siente resistencia, no los apriete más.

Se requieren dos personas para el ensamblaje de este producto. No intente ensamblar este producto e instalar otros equipos sin la debida asistencia de otra persona.

Antes de instalar equipos en este producto, asegúrese de haberlo ensamblado correctamente, a fin de que pueda soportar el peso del equipo que vaya a instalar.

Asegúrese de que ha instalado todo el equipo correctamente antes de efectuar ajustes de este producto.

Por motivos de seguridad, cuando instale o desinstale equipos y esto afecte al peso de la carga instalada, debe seguir los pasos indicados en el manual para reajustar este producto.

¡Peligro de acumulación de energía! La columna de este producto incluye un mecanismo de elevación que puede subir rápidamente cuando desinstale un equipo. Antes de desinstalar un equipo o efectuar ajustes de la tensión de elevación, mueva el monitor hasta la posición más alta de la columna. De lo contrario, pueden producirse lesiones personales o daños en la propiedad.

¡Peligro de vuelco! No desplace el carrito mientras el monitor esté en la posición más alta. Asimismo, no desplace el carrito empujando el monitor.

No desplace el carrito encima de cables o superficies desniveladas.

Antes de empezar a mover el carrito, asegúrese de haber desbloqueado las ruedas. Antes de empezar a mover el carrito, asegúrese de haber desbloqueado las ruedas.

Warnhinweise

Beachten Sie bei der Montage dieses Produkts die Montageanweisungen.

Bevor Sie dieses Produkt montieren und verwenden, lesen Sie das gesamte Handbuch und vergewissern Sie sich, dass Sie die Anweisungen verstanden haben.

Überschreiten Sie nicht die Tragkraft dieses Produkts. Ein Überladen dieses Produkts kann zu Verletzungen oder zur Beschädigung des Produkts führen.

Gewichtskapazität des Multimedia Fachbodens: 5 kg

Gewichtskapazität des Kamera Fachbodens: 5 kg

Gewichtskapazität der TV Halterung: 8-20 kg

Gestatten Sie Kindern nicht, auf das Produkt zu klettern oder das Produkt ohne Aufsicht zu benutzen.

Dieses Produkt ist nur zum Gebrauch in Innenräumen vorgesehen und sollte nicht im Freien verwendet werden.

Achten Sie bei der Montage des Produkts darauf, die Schrauben nicht zu fest anzuziehen. Sobald Sie beim Anziehen der Schrauben auf Widerstand stoßen, stellen Sie das Anziehen ein.

Die Montage dieses Produkts ist auf die Ausführung von zwei Personen ausgelegt. Versuchen Sie nicht ohne Hilfe, dieses Produkt zu montieren und installieren zu lassen.

Bevor Sie Geräte zu diesem Produkt hinzufügen, vergewissern Sie sich, dass Sie es ordnungsgemäß montiert und installiert haben und dass das Produkt das Gewicht der Geräte, die Sie hinzufügen möchten, tragen kann.

Sorgen Sie dafür, dass all Ihre Geräte ordentlich installiert sind, bevor Sie dieses Produkt justieren.

Befolgen Sie aus Sicherheitsgründen die im Benutzerhandbuch beschriebenen Schritte zur Neujustierung des Produkts, wenn Sie Geräte hinzufügen oder entfernen und somit die Traglast verändern.

Gefährdung durch gespeicherte Energie! Die Stütze dieses Produkts enthält einen Hubmechanismus, der sich bei Entnahme der enthaltenen Geräte schnell nach oben bewegen kann. Bringen Sie das Display in die höchste Position der Stütze, bevor Sie Geräte entnehmen oder die Hublast verändern. Andernfalls kann es zu Verletzungen oder zur Beschädigung des Produkts kommen.

Kippgefahr! Bewegen Sie den Wagen nicht, wenn sich das Display in der höchsten Position befindet. Bewegen Sie zudem den Wagen nicht durch Drücken auf das Display.

Bewegen Sie den Wagen nicht über Leitungen, Kabel oder unebenes Gelände.

Stellen Sie sicher, dass die Rollen entriegelt sind, bevor Sie den Wagen in Bewegung setzen.

Table of Contents

Warnings	i
Introduction	1
Product dimensions	1
Product diagram.....	2
Technical specifications	3
Package contents.....	4
Requirements.....	10
Assembly.....	11
Assemble the base.....	11
Adjust the height of the casters.....	12
Attach the column to the base.....	13
Assemble the TV mount	16
Attach the support plate to the column.....	17
Move the support plate to the lowest position	19
Attach the adapter brackets to a flush mounting surface	21
Attach the adapter brackets to a recessed mounting surface.....	23
Attach the TV to the column.....	26
Counterbalance the weight of the TV.....	29
Attach the plastic cover	30
Attach the cable clips	32
Install the multimedia shelf.....	33
Attach the camera shelf.....	36
Attach the wrench	38

Adjusting the STNDMTV70.....	39
Change the orientation of the TV.....	39
Adjust the angle of the TV	40
Adjust the height of the multimedia shelf.....	41
Adjust the height of the camera shelf	42
Lock the vertical position of the TV	43
Technical support.....	44
Warranty information	44

Introduction

Product dimensions

Support plate rotation: 0° to $+90^{\circ}$

TV tilt: $+5^{\circ}$ to -12°

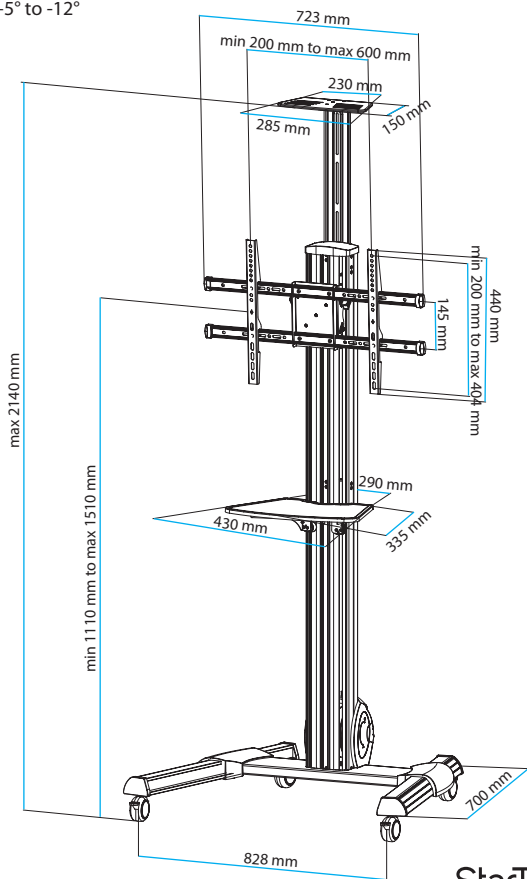

Product diagram

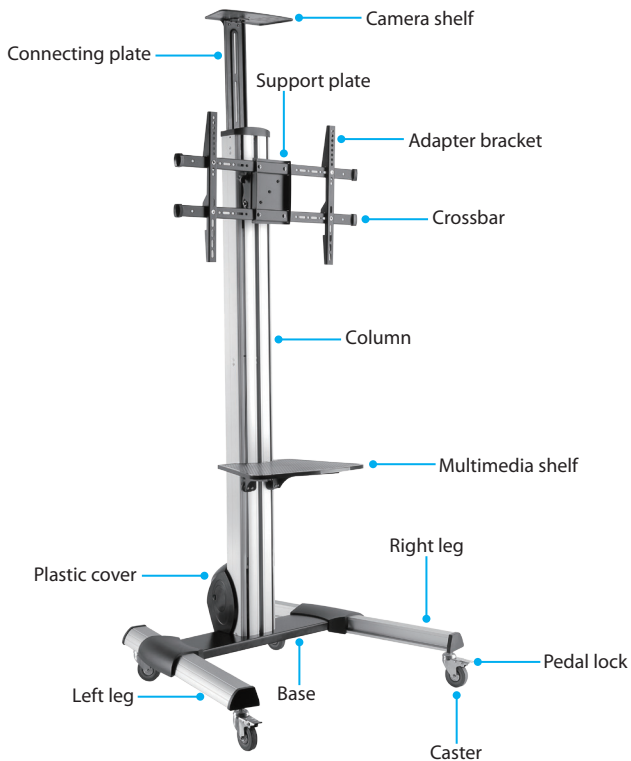

Technical specifications

Unless otherwise indicated, the technical specifications in the table below apply to the TV.

Type of measurement	Measurement
VESA mounting hole pattern on the TV mount 	200x200 300x300 400x200 400x400 600x400
Weight capacity of TV mount 	8 to 20 kg (18 to 44 lb.)
Weight capacity of multimedia shelf 	5 kg (11 lb.)
Weight capacity of camera shelf 	5 kg (11 lb.)
Screen size 	32" to 70"

Package contents

1



Base
Qty: One

2



Left leg
Qty: One

3



Right leg
Qty: One

4



Left base cover
Qty: One

5

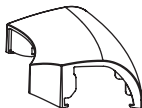

Right base cover
Qty: One

6



Left support bracket
Qty: One

7



Right support bracket

Qty: One

8



Column cover

Qty: One

9



Column

Qty: One

10



Multimedia shelf

Qty: One

11



Camera shelf

Qty: One

12

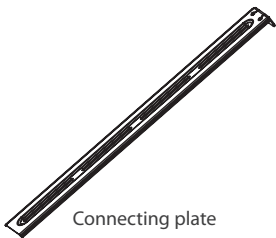

Connecting plate

Qty: One

13

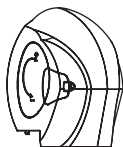

Plastic cover

Qty: One

14



Cable clips

Qty: Three

15

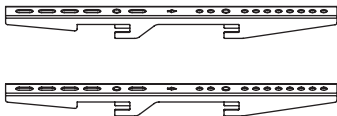

Adapter brackets

Qty: Two

16



Crossbars

Qty: Two

17



End caps

Qty: Four

18

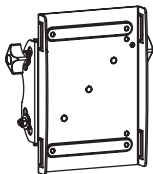

Support plate

Qty: One

19



Wrench
Qty: One

20

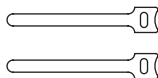

Hook-and-loop ties
Qty: Two

21

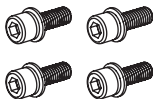

M6x16 mm screws
Qty: Four

22



M6x25 mm screws
Qty: Two

23



Support plate nuts
Qty: Two

24



Countersunk screws
Qty: Three

25

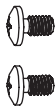

M4x6 mm screws

Qty: Two

26

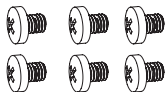

M6x8 mm screws

Qty: Six

27



M6x14 mm screws

Qty: Ten

28

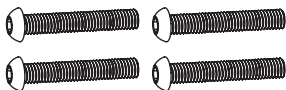

M8x25 mm screws

Qty: Four

29

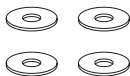

Washers

Qty: Four

30



Shelf spacers

Qty: Four

31



Hex key
Qty: One

32



Castor wrench
Qty: One

33



M5x14 mm screws
Qty: Four

34

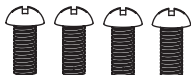

M6x14 mm screws
Qty: Four

35

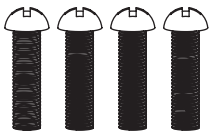

M6x30 mm screws
Qty: Four

36

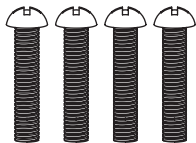

M8x30 mm screws
Qty: Four

37

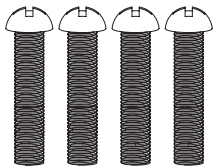

M8x50 mm screws

Qty: Four

38

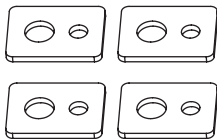

TV washers

Qty: Four

39

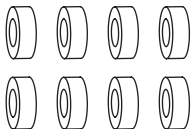

Small spacers

Qty: Eight

40

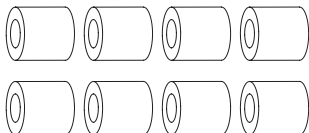

Large spacers

Qty: Eight

41



Instruction manual

Qty: One

Requirements

- A TV that is compatible with one of the VESA mounting hole patterns STNDMTV70 supports
- A Phillips™ type screwdriver

Requirements are subject to change. For the latest requirements, please visit www.StarTech.com/STNDMTV70.

Assembly

Warning! Assembling this product requires multiple people. DO NOT attempt to assemble this product and install equipment without assistance.

Assemble the base

1. Insert the base into the left leg, aligning the holes in the base with the holes in the left leg.
2. Insert two M6x16 mm screws through the left leg and into the base.
3. Use the hex key to tighten the M6x16 mm screws.
4. Repeat steps 1 to 3 to attach the right leg. (figure 1)

figure 1

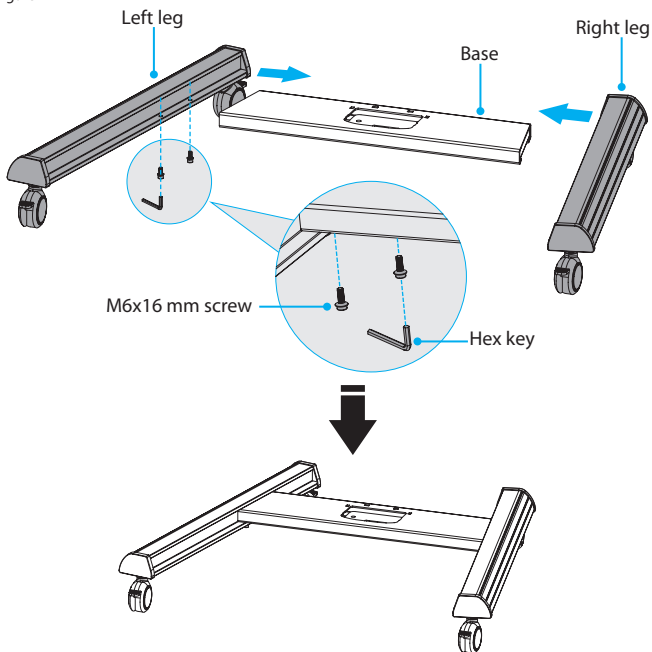

Adjust the height of the casters

You can adjust the height of each of the four casters so that the casters are balanced and the assembly doesn't rock.

1. Use the caster wrench to loosen the nuts above the casters.
2. Rotate the casters counterclockwise or clockwise to raise or lower the casters to the desired height.
3. Use the caster wrench to tighten the nuts. (figure 2)

figure 2

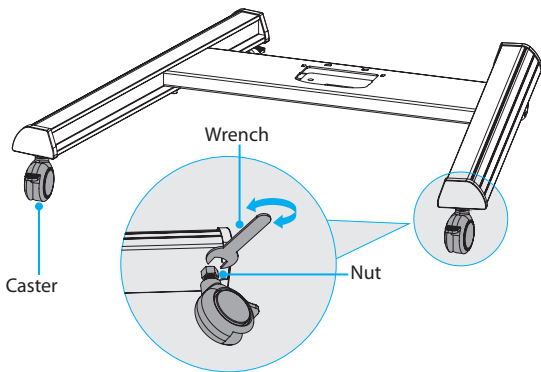

Attach the column to the base

1. Snap the column cover onto the top of the column. (*figure 3*)

figure 3

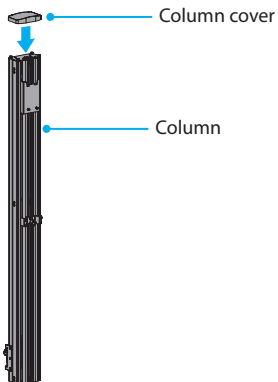

2. Press the pedal locks down on each of the casters to lock them in place and prevent the legs from moving as you attach the column. (*figure 4*)

figure 4

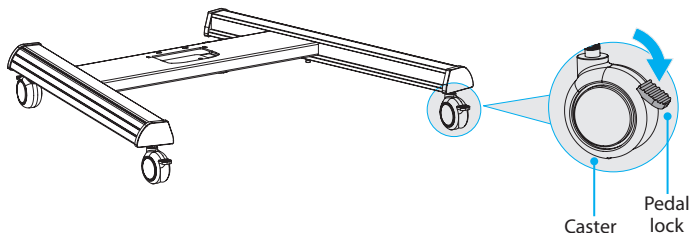

3. Line up the holes in the bottom of the column with the holes in the base.
4. While another person holds the column upright, insert the four M8x25 mm screws through the base and into the column.
5. Use the hex key to tighten the M8x25 mm screws. (figure 5)

figure 5

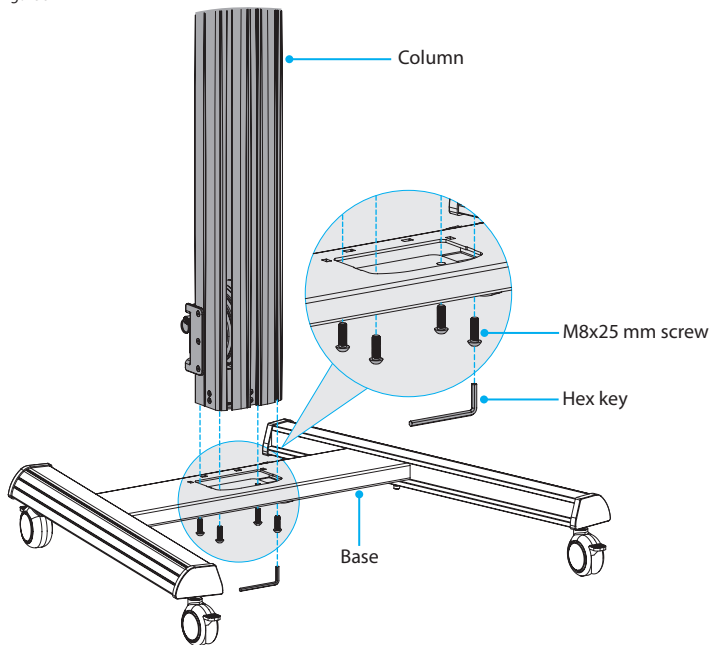

6. Snap the left base cover and the right base cover onto the base and legs. (figure 6)

figure 6

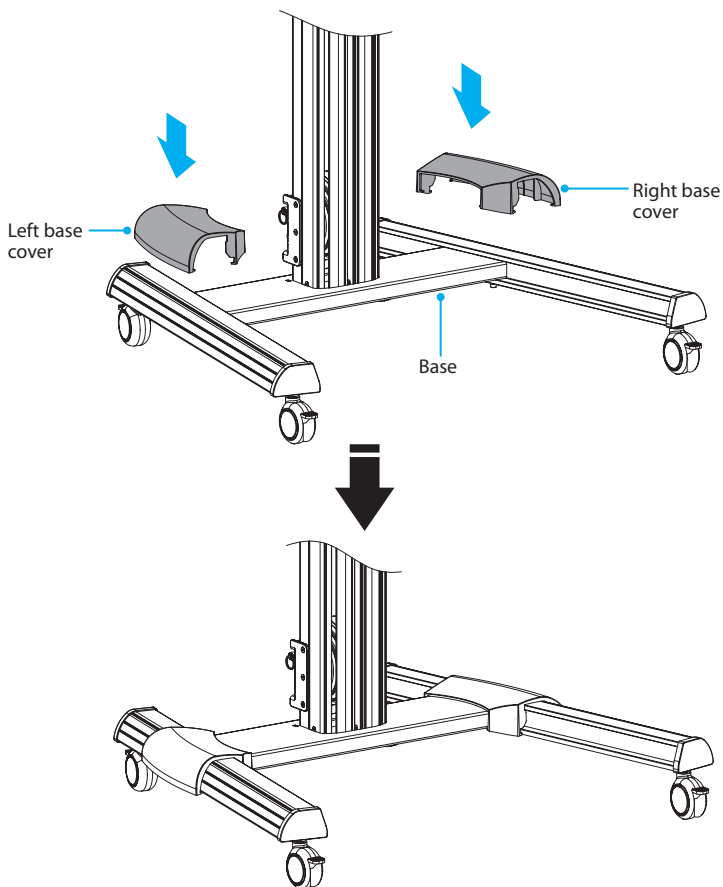

Assemble the TV mount

1. Slide the crossbars through the top and bottom openings in the support plate. (figure 7)

figure 7

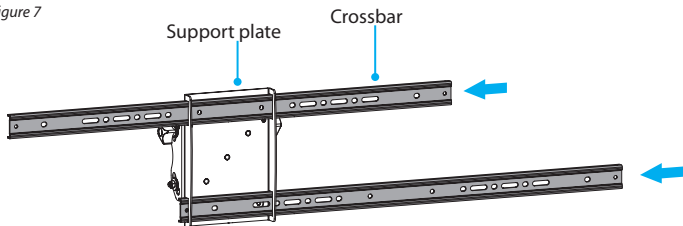

2. Position the crossbars so that they are centered on the support plate and the holes on the crossbars are aligned with the holes in the support plate.
3. Insert four of the M6x14 mm screws through the crossbars and into the support plate. (figure 8)
4. Use a Phillips type screwdriver to tighten the M6x14 mm screws.

figure 8

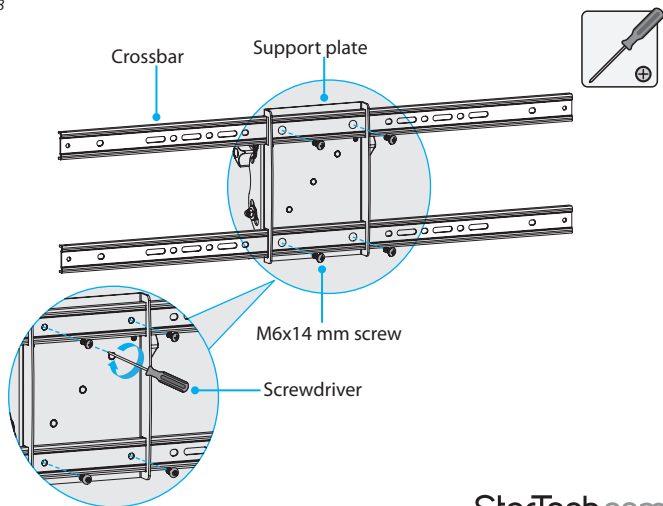

5. Snap an end cap onto each of the four ends of the crossbars. (figure 9)

figure 9

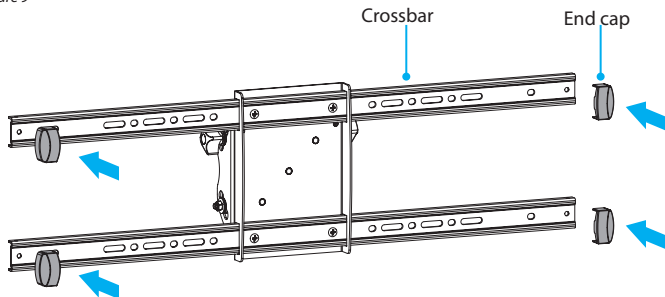

Attach the support plate to the column

1. Lift up the support plate and hook the top of the support plate onto the protrusion and the studs on the column. (figure 10)

figure 10

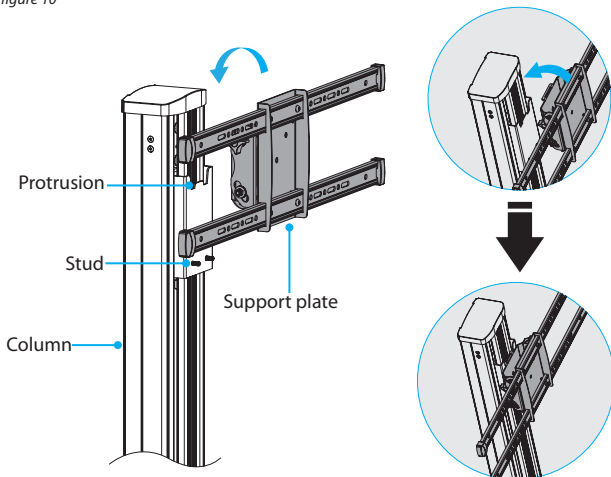

2. Place the support plate nuts over the studs on the column and use your fingers to tighten the support plate nuts.
3. Use the wrench to finish tightening the support plate nuts. (*figure 11*)

figure 11

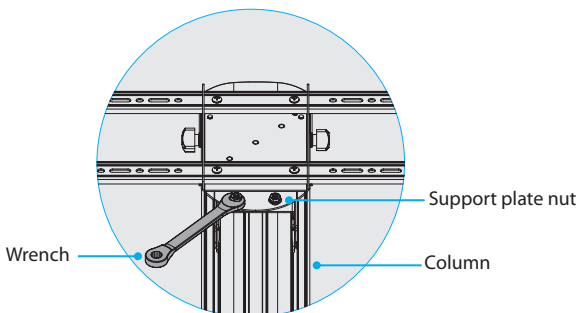

Move the support plate to the lowest position

When the spring-loaded pin is positioned in one of the holes in the side of the spool at the bottom of the column, the vertical position of the TV is locked and you can't move the TV up or down the column. (figure 12)

If you pull the pin out of the spool and turn it to the unlocked position (figure 12), the TV is no longer locked in place and can be moved up or down the column.

Caution! You should avoid leaving the pin in the unlocked position.

Warning! Exercise caution when you pull the pin out of the spool and turn it to the unlocked position. The weight of the TV or support plate may not be counterbalanced and could free fall down the column or spring upwards, resulting in damage to the TV or support plate, or personal injury.

figure 12

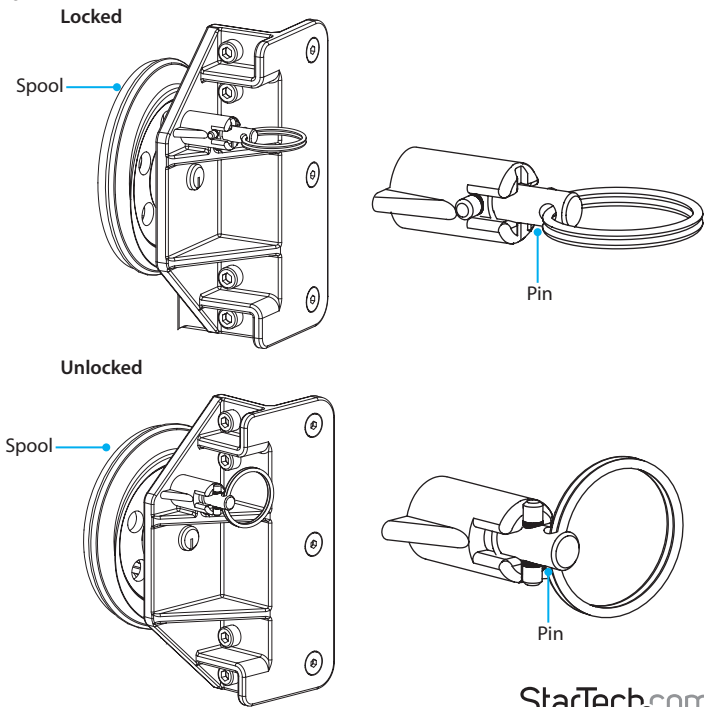

1. To unlock the vertical position of the support plate, at the bottom of the column, next to the spool, pull the pin out and turn it to the unlocked position. (figure 13)

figure 13

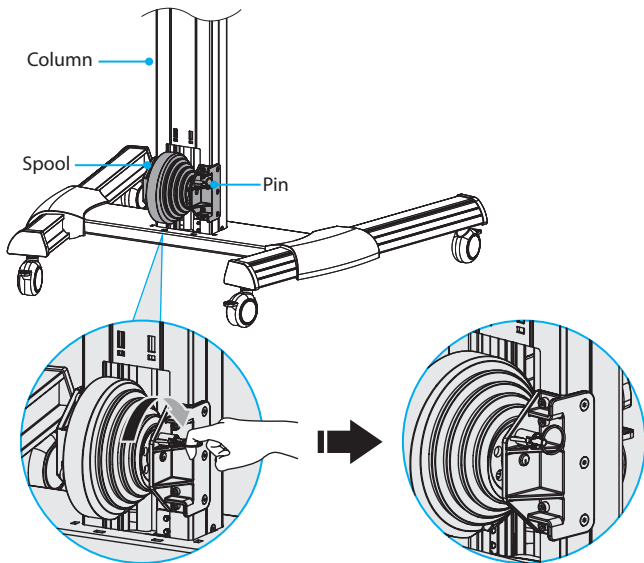

2. Pull the support plate and adapter brackets down until they are at the bottom of the column.
3. Pull the pin and turn it to the locked position.
4. To make sure that the pin is properly aligned in one of the holes, pull up or push down on the support plate. You may hear a clicking sound as the spring-loaded pin goes into the hole and prevents the spool from rotating.

Caution! If the pin is misaligned and isn't fully inserted into one of the holes on the spool, the vertical position isn't locked and the TV could free fall down the column or spring upwards, resulting in damage to the TV or personal injury.

When the pin is aligned in one of the holes and the support plate is locked in place, it shouldn't move if you pull up or push down on it.

Attach the adapter brackets to a flush mounting surface

To accommodate different TV designs, the STNDMTV70 comes with five sets of screws of different lengths and diameters, TV washers with two hole sizes, and two sizes of spacers.

Warning! Make sure that the weight of the TV doesn't exceed the weight capacity of this product. If you exceed the weight capacity, you might experience personal injury or damage to the product.

This product can support the following weight: between 8 and 20 kg (18 to 44 lb.).

1. To select the combination of mounting hardware that you need to use to attach the adapter brackets to the TV, complete the following:

- Determine the depth of the mounting holes on the TV.
- Determine the diameter of the mounting holes on the TV.

Note: If you're using a TV with a flush mounting surface, you don't need to use any of the provided spacers.

2. Position the adapter brackets so that the hooks on the adapter brackets are pointed towards the bottom of the TV and are aligned with the mounting holes on the back of the TV.

3. Depending on the screw size that you're using, place the TV washers so that either the small or large holes are positioned over the adapter brackets.

4. Insert the M5x14 mm screws or the M6x14 mm screws through the TV washers, adapter brackets, and into the back of the TV.

5. Use a Phillips type screwdriver to tighten the screws. (*figure 14*)

Warning! Do not over-tighten the screws. If you encounter resistance while you're tightening the screws, stop tightening. Failure to do so could result in damage to the TV.

figure 14

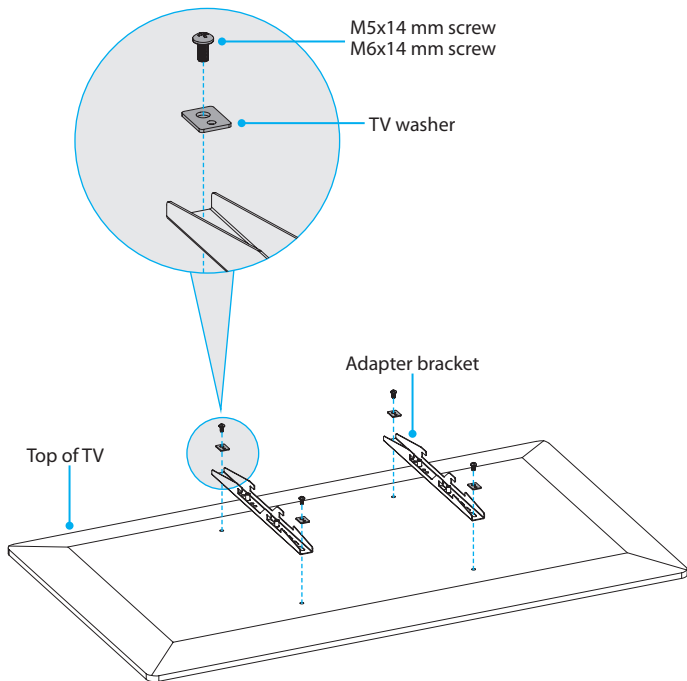
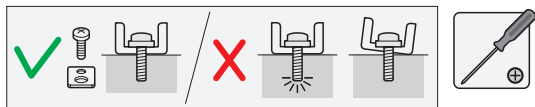

Attach the adapter brackets to a recessed mounting surface

To accommodate different TV designs, the STNDMTV70 comes with five sets of screws of different lengths and diameters, TV washers with two hole sizes, and two sizes of spacers.

Warning! Make sure that the weight of the TV doesn't exceed the weight capacity of this product. If you exceed the weight capacity, you might experience personal injury or damage to the product.

This product can support the following weight: between 8 and 20 kg (18 to 44 lb.).

1. To select the combination of mounting hardware that you need to use to attach the adapter brackets to the TV, complete the following:
 - Determine the depth of the mounting holes on the TV.
 - Determine the diameter of the mounting holes on the TV.
2. Consult the images below and on the next page to see the different hardware combinations available, and select the one that works best with the TV.

M6x30 mm screw



or

M8x30 mm screw

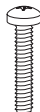

combined with



or

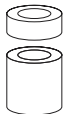

or



2 small spacers

1 small spacer
1 large spacer

1 large spacer

M8x50 mm hardware combinations are illustrated on the next page

M8x50 mm

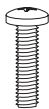

combined with

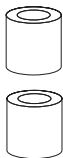

or



or

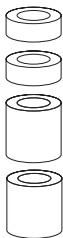

2 large spacers

1 small spacer
2 large spacers

2 small spacers
2 large spacers

3. Position the adapter brackets so that the hooks on the adapter brackets are pointed towards the bottom of the TV and are aligned with the mounting holes on the back of the TV.
4. Depending on the screw size that you're using, place the TV washers so that either the small or large holes are positioned over the adapter brackets.
5. Insert the M6x30 mm screws, M8x30 mm screws, or the M8x50 mm screws through the TV washers, adapter brackets, spacers, and into the back of the TV.
6. Use a Phillips type screwdriver to tighten the screws. (figure 15)

Warning! Do not over-tighten the screws. If you encounter resistance while you're tightening the screws, stop tightening. Failure to do so could result in damage to the TV.

figure 15

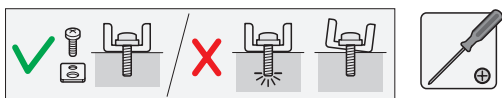

M6x30 mm screw

M8x30 mm screw

M8x50 mm screw

TV washer

Spacers

Adapter bracket

Top of TV

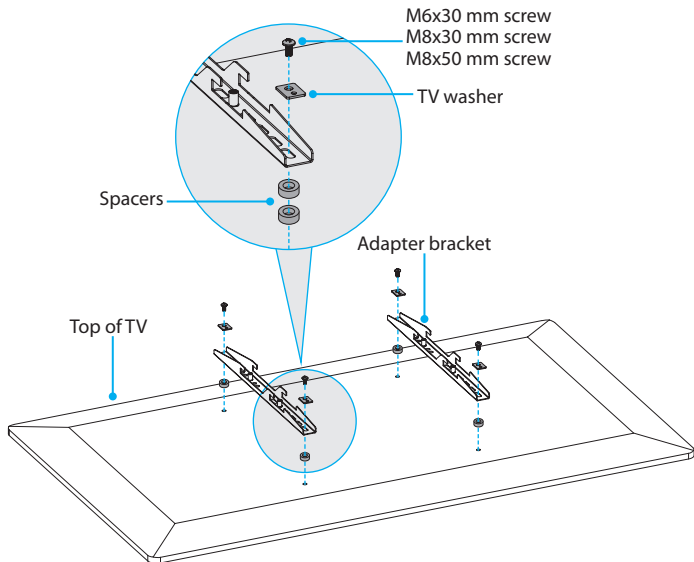

Attach the TV to the column

Warning! Attaching the TV requires multiple people. Do not attempt to complete this task by yourself.

Warning! Make sure that you move the support plate to the lowest position on the column before you attach the TV. For more information, see the “Move the support plate to the lowest position” section.

1. If you haven't done so already, press the pedal locks down on each of the casters to prevent the legs from moving as you attach the TV to the column.
2. With a person holding each side of the TV, carefully lift up the TV and hook the adapter brackets over the crossbars. (figure 16)

figure 16

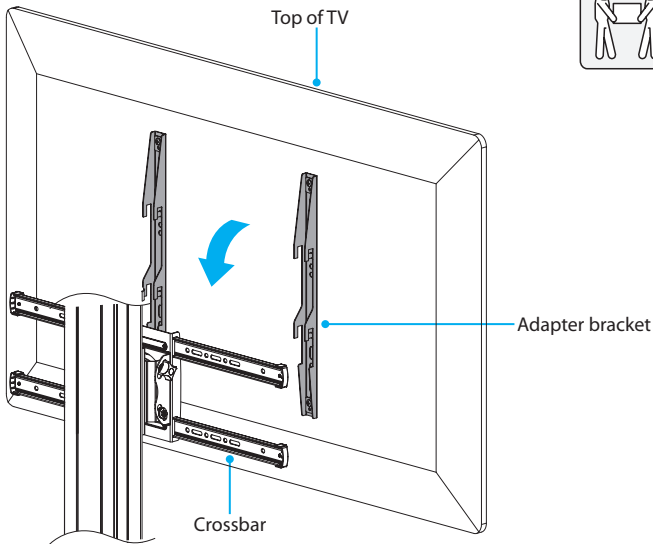

- Center the TV on the crossbars, and insert four M6x14 mm screws through the crossbars and into the adapter brackets. (figure 17)
- Use a Phillips type screwdriver to tighten the M6x14 mm screws.

figure 17

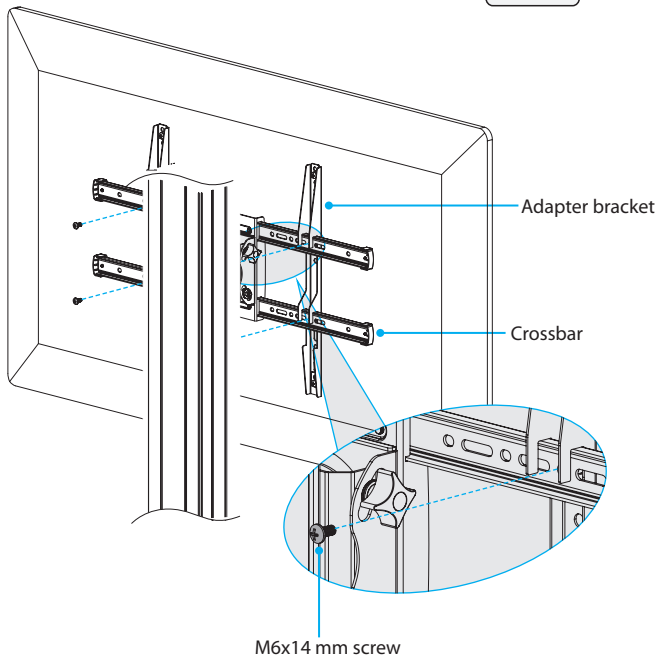

5. To secure the TV in the landscape position, insert two of the M6x8 mm screws into the support plate and use a Phillips type screwdriver to tighten the screws.

(figure 18)

To move the TV into portrait orientation, see the "Change the orientation of the TV" section.

figure 18

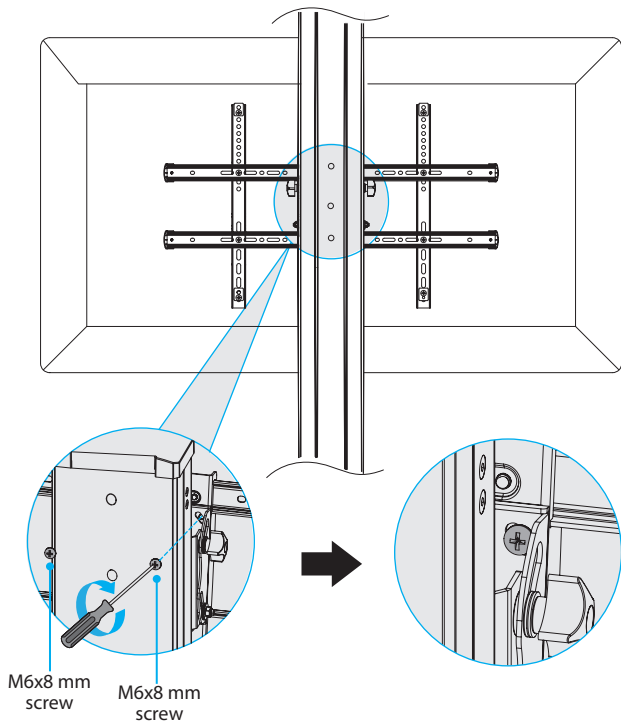

Counterbalance the weight of the TV

When you add a TV to the STNDMTV70, you need to adjust the lift capacity of the TV cart to support the weight of the TV. If the lift capacity of the STNDMTV70 isn't set correctly, when you let go of the TV, it could free fall down the column or move up the column unaided, resulting in damage to the TV or personal injury.

Warning! Counterbalancing the weight of the TV requires multiple people. Do not attempt to complete this task by yourself.

1. At the bottom of the column, pull the pin out of the spool and turn it to the unlocked position.
2. Move the TV up the column a short distance and loosen your hold on the TV to see if it remains stationary. Based on what you observe, do one of the following:
 - If the TV rises up the column, use the wrench to turn the knob near the spool clockwise. (figure 19)
 - If the TV falls down the column, use the wrench to turn the knob near the spool counterclockwise. (figure 19)

Warning! If you encounter resistance when you turn the knob, stop turning it. If you continue to turn the knob, you may damage the TV cart.

Note: To counterbalance the weight of the TV, you may need to turn the knob near the spool up to 80 full revolutions.

figure 19

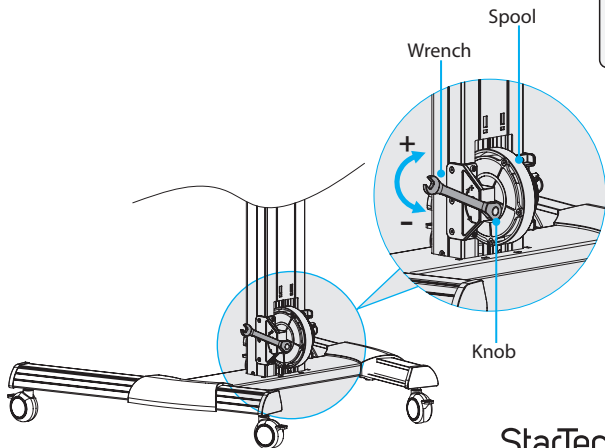

3. Repeat step 2 until the weight of the TV is counterbalanced.

Note: When the weight of the TV is properly counterbalanced, the TV will remain stationary on the column when you loosen your hold on it, and you will be able to move the TV up or down the column with minimal effort.

4. When the weight of the TV is counterbalanced, move the TV to the desired height.

5. Pull the pin and turn it to the locked position.

6. To make sure that the pin is properly aligned in one of the holes in the spool, pull up or push down on the TV. You may hear a clicking sound as the spring-loaded pin goes into a hole and prevents the spool from rotating.

When the pin is aligned in one of the holes and the TV is locked in a vertical position, the TV shouldn't move when you pull up or push down on it.

Caution! If the pin is misaligned and isn't fully inserted into one of the holes on the spool, the vertical position isn't locked and the TV could free fall down the column or spring upwards, resulting in damage to the TV or personal injury.

Warning! The degree of the lift strength that you set the STNDMTV70 to depends upon the weight of the TV. Every time that you take a TV off of the STNDMTV70 and add a different TV, you must counterbalance the weight of the TV again.

Attach the plastic cover

Caution! Exercise caution when you assemble the plastic cover because the tabs on the plastic cover can be broken off easily if you use excess force during assembly.

1. Carefully separate the two halves of the plastic cover. (figure 20)

figure 20

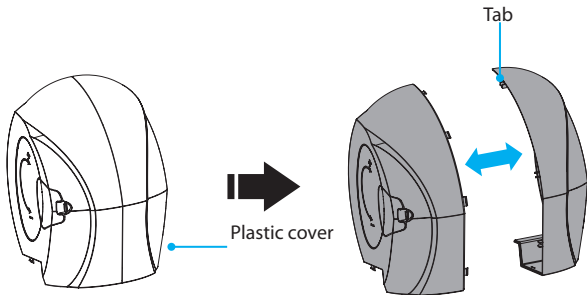

2. Place the two halves of the plastic cover around the spool and snap the two sides together.
3. Move the assembled plastic cover in towards the column and carefully hook the tabs on the top of the plastic cover into the slots on the column.
4. Press the plastic cover down towards the base and snap the tabs on the plastic cover into the holes on the column and the base. (figure 21)

figure 21

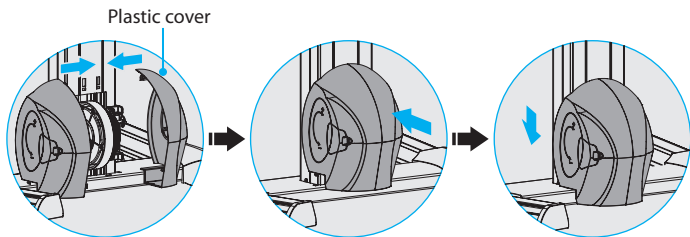
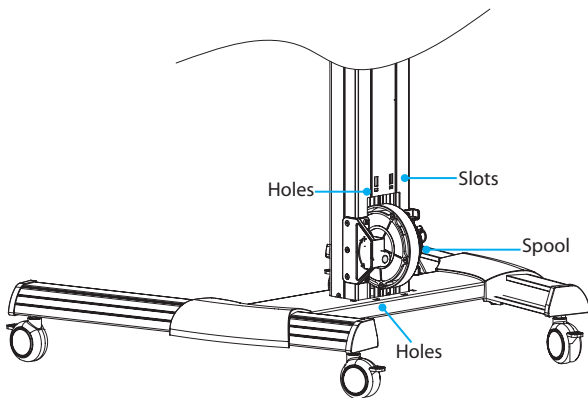

Attach the cable clips

1. Remove the backing from the cable clips.
2. Attach the cable clips along the column.
3. Route the cables down the column and through the cable clips.
4. Snap the cable clips closed. (*figure 22*)

figure 22

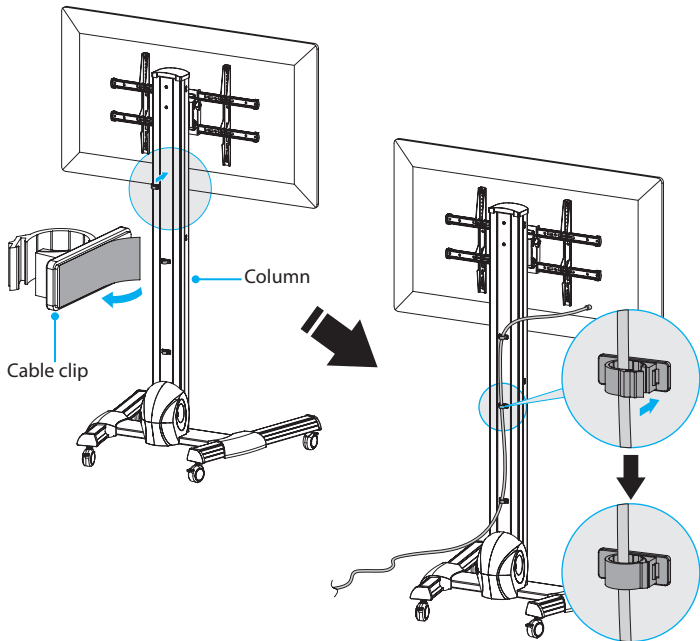

Install the multimedia shelf

1. Place the shelf spacers over the projections on the underside of the multimedia shelf.
2. Position the right and left support brackets over the washers so that the holes are aligned and the scalloped edges of the adapter brackets are pointed towards the outside edges of the multimedia shelf.
3. Place the washers over the holes in the adapter brackets, and insert the M6x8 mm screws through the washers, adapter brackets, and into the projections on the multimedia shelf.
4. Use a Phillips type screwdriver to tighten the M6x8 mm screws. (figure 23)

figure 23

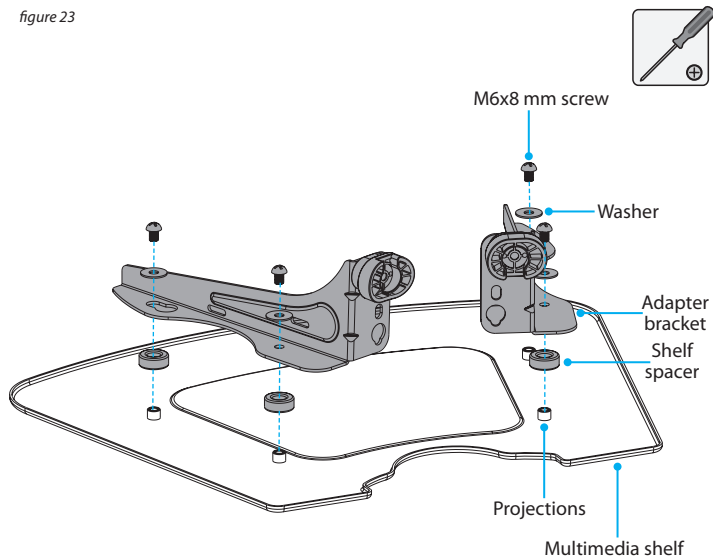

5. Turn the knob on the shelf bracket counterclockwise to loosen it.
6. Move the shelf bracket to the height that you want the multimedia shelf to be at, and turn the knob clockwise to tighten it. (figure 24)

figure 24

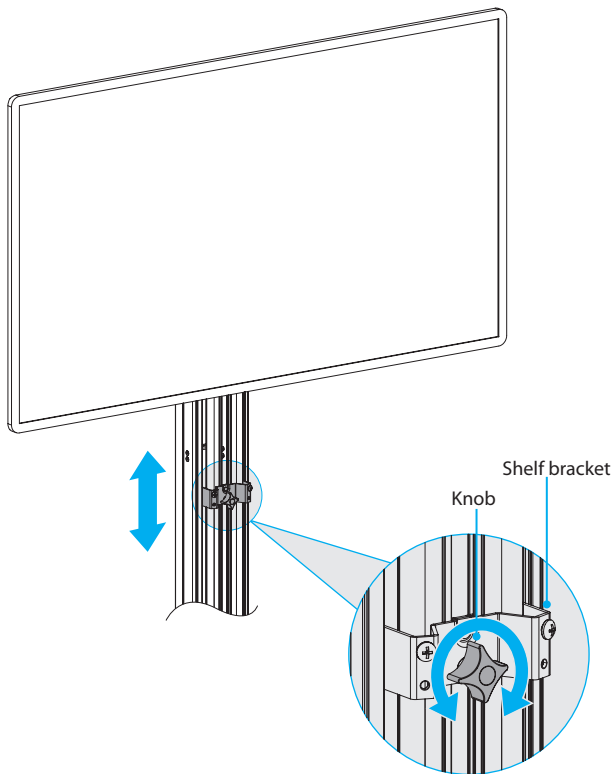

- Hook the multimedia shelf over the screws in the shelf bracket and slide the multimedia shelf downwards.
- Insert two M6x14 mm screws into the multimedia shelf and into the shelf bracket.
- Use a Phillips type screwdriver to tighten all four of the M6x14 mm screws. (figure 25)

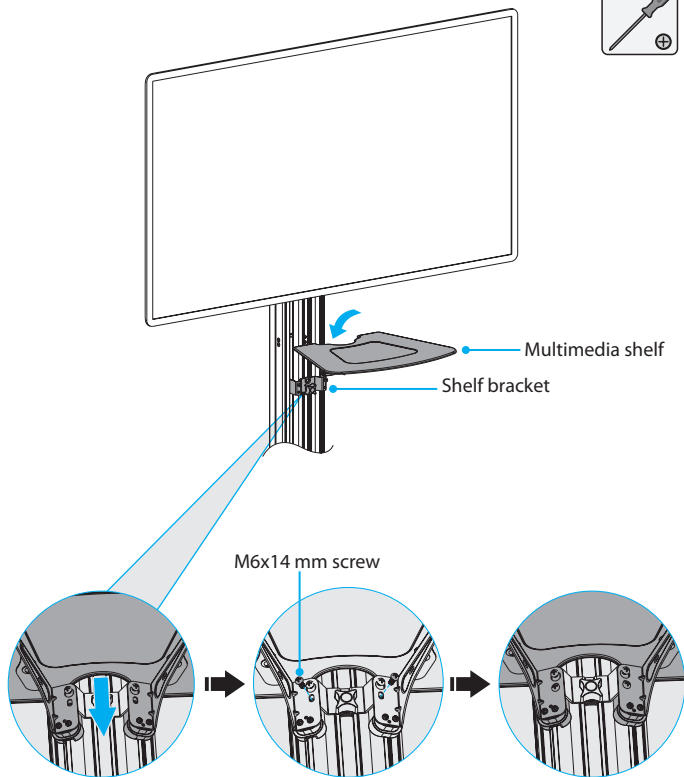

Attach the camera shelf

1. Line up the holes on the camera shelf with the holes on the end of the connecting plate.
2. Insert the three countersunk screws through the top of the camera shelf and into the connecting plate.
3. Use a Phillips type screwdriver to tighten the countersunk screws. (figure 26)

figure 26

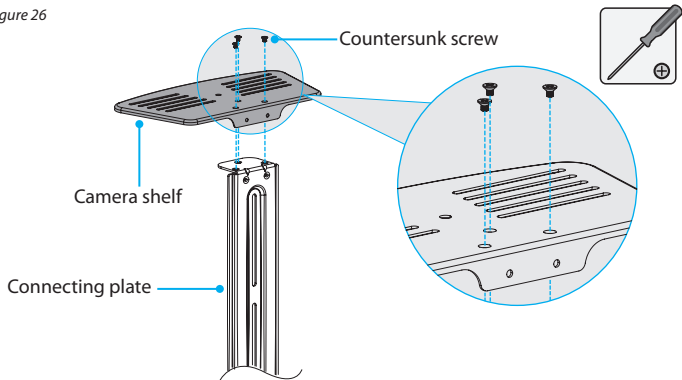

4. Insert the two M4x6 mm screws into the camera shelf and into the side of the connecting plate. (figure 27)
5. Use a Phillips type screwdriver to tighten the screws in place.

figure 27

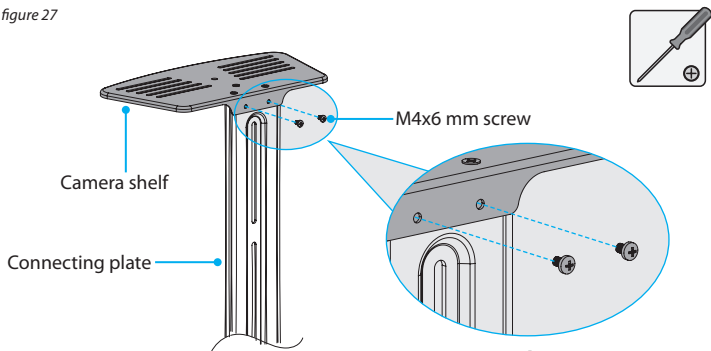

- Determine the height that you want the camera shelf to be at and line it up with the mounting slots on the back of the column.
- Insert the two M6x25 mm screws through the connecting plate and into the column. (figure 28)
- Use a Phillips type screwdriver to tighten the screws in place.

figure 28

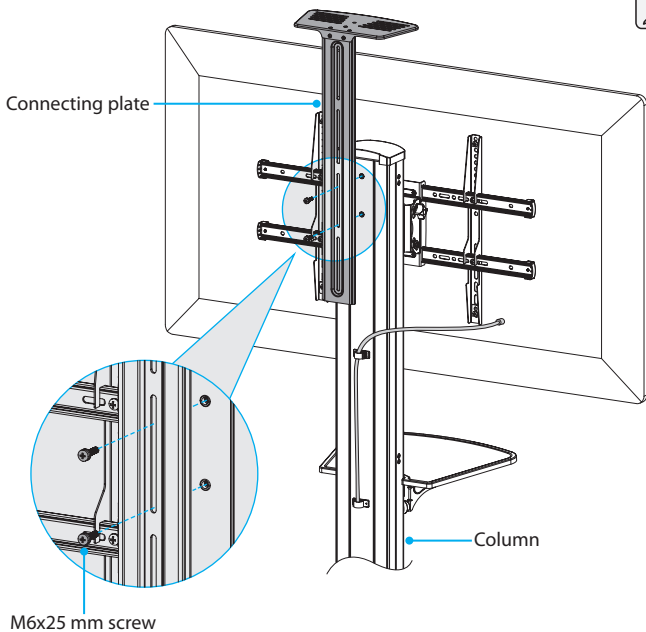

Attach the wrench

1. Thread the two hook-and-loop ties through the hole in one of the support brackets under the multimedia shelf.
2. Hold the wrench against the support bracket and wrap the hook-and-loop ties around the wrench. (*figure 29*)

figure 29

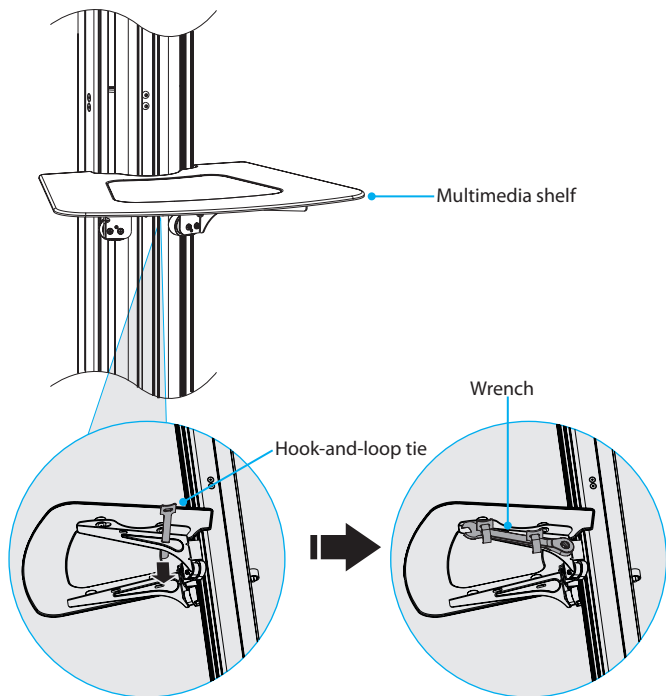

Adjusting the STNDMTV70

Change the orientation of the TV

You can position the TV in either landscape or portrait orientation on the STNDMTV70.

1. To display the TV in portrait orientation, if present, remove the two M6x8 mm screws from the back of the support plate.
2. Rotate the TV 90° clockwise.
3. Reinsert the M6x8 mm screws you removed in step 1, and use a Phillips type screwdriver to tighten them. (figure 30)

figure 30

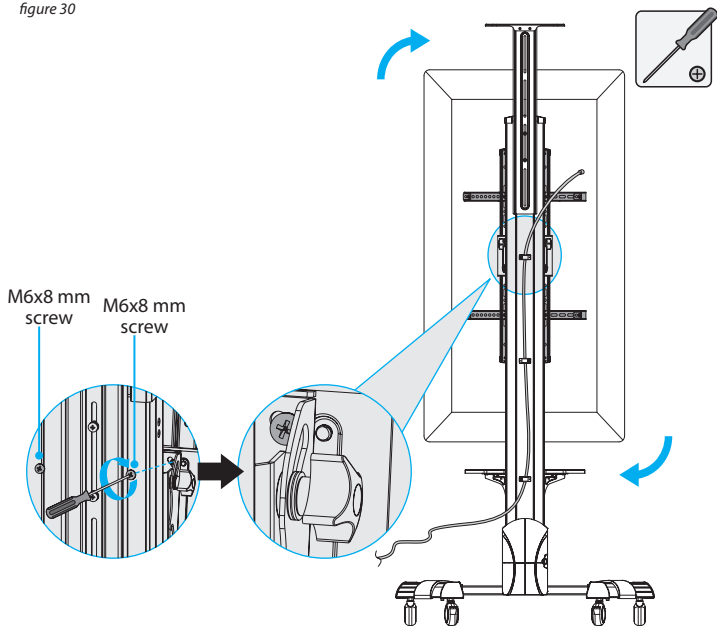

Adjust the angle of the TV

1. Turn the knobs on either side of the support plate counterclockwise to loosen them.
2. Push or pull the top or bottom of the TV to adjust the angle of the TV.
3. Turn the knobs on either side of the support plate clockwise to tighten them.
(figure 31)

figure 31

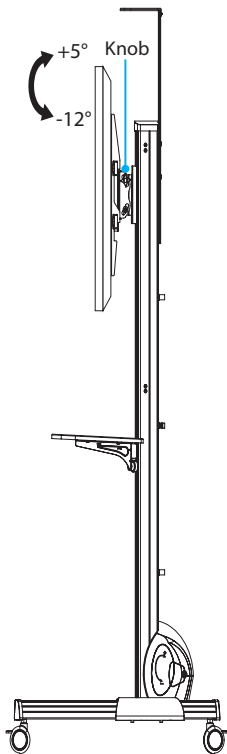

Adjust the height of the multimedia shelf

1. Under the multimedia shelf, turn the knob counterclockwise.
2. Move the multimedia shelf to the desired height, and turn the knob clockwise to tighten it into place. (*figure 32*)

figure 32

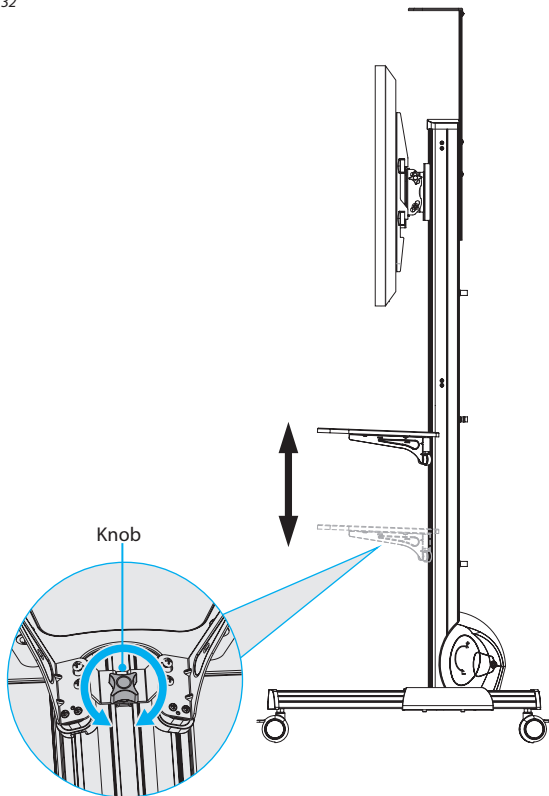

Adjust the height of the camera shelf

1. Loosen the two M6x25 mm screws attaching the connecting plate to the column.
2. Move the connecting plate to the desired height, and use a Phillips type screwdriver to tighten the M6x25 mm screws into place. (*figure 33*)

figure 33

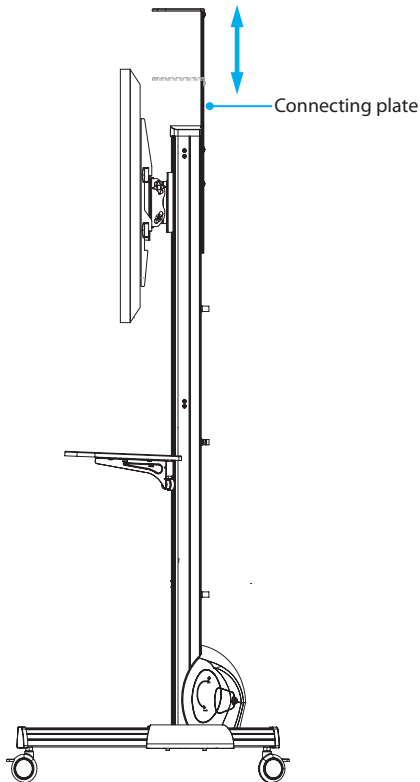

Lock the vertical position of the TV

When the TV is at the height that you want it to be at, you should lock the vertical position of the TV to prevent the TV from moving up or down the column.

Warning! Exercise caution when you pull the pin out of the spool and turn it to the unlocked position. The weight of the TV may not be counterbalanced and the TV could free fall down the column or spring upwards, resulting in damage to the TV or personal injury.

1. Pull the pin out of the spool and turn it to the unlocked position.
2. If necessary, adjust the height of the TV.
3. Pull the pin and turn it to the locked position.
4. To make sure that the pin is properly aligned in one of the holes in the spool, pull up or push down on the TV. You may hear a clicking sound as the spring-loaded pin goes into the hole and prevents the spool from rotating.

When the pin is aligned in one of the holes and the TV is locked in a vertical position, the TV shouldn't move when you pull up or push down on it.

Caution! If the pin is misaligned and isn't fully inserted into one of the holes on the spool, the vertical position isn't locked and the TV could free fall down the column or spring upwards, resulting in damage to the TV or personal injury.

5. Close the door on the plastic cover.

Technical support

StarTech.com's lifetime technical support is an integral part of our commitment to provide industry-leading solutions. If you ever need help with your product, visit www.startech.com/support and access our comprehensive selection of online tools, documentation, and downloads.

For the latest drivers/software, please visit www.startech.com/downloads

Warranty information

This product is backed by a two-year warranty.

StarTech.com warrants its products against defects in materials and workmanship for the periods noted, following the initial date of purchase. During this period, the products may be returned for repair, or replacement with equivalent products at our discretion. The warranty covers parts and labor costs only. StarTech.com does not warrant its products from defects or damages arising from misuse, abuse, alteration, or normal wear and tear.

Limitation of liability

In no event shall the liability of StarTech.com Ltd. and StarTech.com USA LLP (or their officers, directors, employees or agents) for any damages (whether direct or indirect, special, punitive, incidental, consequential, or otherwise), loss of profits, loss of business, or any pecuniary loss, arising out of or related to the use of the product exceed the actual price paid for the product. Some states do not allow the exclusion or limitation of incidental or consequential damages. If such laws apply, the limitations or exclusions contained in this statement may not apply to you.

Hard-to-find made easy. At StarTech.com, that isn't a slogan. It's a promise.

StarTech.com is your one-stop source for every connectivity part you need. From the latest technology to legacy products — and all the parts that bridge the old and new — we can help you find the parts that connect your solutions.

We make it easy to locate the parts, and we quickly deliver them wherever they need to go. Just talk to one of our tech advisors or visit our website. You'll be connected to the products you need in no time.

Visit www.startech.com for complete information on all StarTech.com products and to access exclusive resources and time-saving tools.

StarTech.com is an ISO 9001 Registered manufacturer of connectivity and technology parts. StarTech.com was founded in 1985 and has operations in the United States, Canada, the United Kingdom and Taiwan servicing a worldwide market.